



TR-3000 Digital Fault Recorder

FOR GENERATION, TRANSMISSION, AND DISTRIBUTION POWER SYSTEM MONITORING



MULTI-FUNCTION RECORDER

The TR-3000 is the only tool you need to capture and diagnose power system anomalies. With multiple recording modes and continuous transient oscillography, you will never miss an event. The TR-3000 captures high speed transients and long term system disturbances with enough memory to give you a complete view of the system disturbance. While simple and quick to set up and diagnose a fault, it has the power to analyze complex system anomalies.

Multi-Function Capability

The TR-3000 takes the place of several devices, by providing fault and disturbance recording, continuous logging, power quality monitoring and sequence of events recording. It integrates these functions into one unit, saving you money on equipment and installation. All recording modes operate simultaneously and independently to provide a complete picture of your system event. It's the ideal tool to help you optimize your power system to provide fault location, improve reliability, shorten fault clearance times, and verify correct operation of your switchgear and protection equipment.

Ease of Use

The TR-3000 is easy to configure, install and operate using the same field proven display station software used in other AMETEK Fault Recorders. The TR-3000 goes one step further with all system parameters configured by software including the selection of current and voltage inputs. The compact modular architecture is suited for small or large applications by adding input modules and chassis to fit your needs.

High Reliability

The TR-3000 is a highly reliable solid state design that incorporates a low-power fan-less operation with no moving parts and a 256 GB solid state drive for long term storage. Each chassis can be equipped with a redundant power supply which can operate from the same or different power source. Input modules are hot-swappable and each one has its own dedicated processor for independent monitoring. Multiple independent ethernet ports support simultaneous connections



for reliable network communications and secure data transfers.

Field Proven Technology - Never Miss An Event

The core strength of AMETEK Recorders is the extensive triggering and recording capabilities to ensure you never miss an event. The TR-3000 has a 256GB solid state drive for recording high resolution data at longer durations. The flexible triggering options make it easy to capture a simple fault or uncover a complex system anomaly. Independent of any triggers, the transient oscillography feature provides continuous waveform recording for up to 64* days to capture events that are too sensitive for your triggers or to extend your pre- and post-fault data recorded.

FEATURES AND BENEFITS

- Multiple recording modes—capture high speed transient faults and long term disturbances
- Never miss an event—flexible triggering, continuous transient oscillography, longer recording times
- Ease of use—100% software configurable - no jumpers or switches
- High reliability—256GB solid state memory, no moving parts, redundant power supplies
- Field proven display station software—single software platform for all products
- Synchrophaser (PMU) C37.118.1a-2014
- IEC 61850 (edition 2) MMS & GOOSE
- DNP 3.0



Triggering

The system can be triggered with independent settings for transient and disturbance recording or combined settings for both transient and disturbance recording modes. This allows you to customize the recording for your specific application; including fault analysis, switchgear operation, grid instability, circuit breaker performance and power quality.

Type	Measurement	Trigger	Per Channel	Phase Group	Line Group
Transient and Disturbance Triggers	Voltage/Current	Over, Under, Rate of Change	X		
	Harmonics	Over (THD & 2 Specified Individual Harmonics per Channel)	X		
	Digital Inputs	Level, Edge, Return to Normal	X		
	Phase Group	Zero, Negative, Positive Sequence		X	
	Frequency	Over, Under, Rate of Change	2		
Disturbance Triggers (only)	Voltage Imbalance	Over			X
	PF & Displacement PF	Over, Under, Rate of Change			X
	Impedence	Over, Under, Rate of Change			X
	Phase Difference	Over		X	
	Analog Fundamental	Over, Under, Rate of Change	X		
	Frequency Oscillation*	4 Frequency Bands	2		
	Power Oscillation*	4 Frequency Bands			X
	Power (Watts, VARS, VA)	Over, Under, Rate of Change			X

Recording Modes

The TR-3000 has both triggered recording modes and continuous recording modes. Both recording modes are enabled simultaneously for capturing high resolution data from a system anomaly and performing long term trending. The 256GB solid state drive provides ample storage for all of your data.

Triggered Recording Modes

Type	Measurement	Pre-Trigger Data	Post-Trigger Data
Transient	32-512 Samples/Cycle 1.6-25.6 kHz (50 Hz) 1.9-30.7 kHz (60 Hz)	2 Cycles – 10 Seconds	8 Cycles – 60 Seconds
Disturbance	0.5-2 Samples/Cycle 25-100 kHz (50 Hz) 30-120 kHz (60 Hz)	10 Seconds – 10 Minutes	30 Seconds – 45 Minutes

Continuous Recording Modes

Type	Measurement	Values	Per Channel	Phase Group	Line Group	Recording Interval	Duration
Logger	Voltage/Current	Min/Max/Avg	X			1 Minute	52 Weeks
	Frequency	Min/Max/Avg	2			1 Minute	52 Weeks
	Power (Watts)	Min/Max/Avg			X	1 Minute	52 Weeks
Power Quality	Voltage Imbalance	Min/Max/Avg		X		10 Minute	52 Weeks
	Flicker (Short & Long Term)	Min/Max/Avg			X	10 Minute	52 Weeks
	Harmonics (Voltage/Current)	Magnitude/Phase Angle/Min/Max/Avg (Up to 128th)	X			10 Minute	52 Weeks
SER	Digital Inputs	On/Off	X			msec	52 Weeks
Transient Oscillography	Voltage/Current	Waveform	X			8 to 32 Samples/Cycle (480-1,920 Hz/400-1,600 Hz)	1-64 Days*
Disturbance Logger	Voltage/Current	RMS, Fundamental, Phase Angle	X			30/60/120 Hz (25/50/100 Hz)	14-64 Days*
	Frequency	Magnitude	2			30/60/120 Hz (25/50/100 Hz)	14-64 Days*

Fault recording data is stored in COMTRADE format inside the recorder for convenient retrieval and analysis. All recorded data can be retrieved by date/time frame and at lower resolutions than what was recorded. This lets you quickly retrieve data at lower sample rates with the assurance that high resolution data can be reviewed at another time.

Power Quality Recording

The power quality at your site is recorded automatically with logs to store individual current and voltage Harmonics up to the 128th, Flicker, imbalance, frequency and steady state RMS voltage/current with 52 weeks of internal storage. Data can be retrieved and displayed graphically in the display station analysis software using preconfigured templates for voltage sags and swells, harmonics and comparisons to PQ standards (IEC 61000-4-30 Class A).

Sequence of Events Recording

The digital inputs are timestamped to the millisecond during an event, recording alarms and return to normal states in a separate log.

System Architecture

The 4U chassis holds up to 8 input modules that can accept 6 analog and 12 digital inputs each for a system capacity of 48 analog and 96 digital inputs. Multiple chassis can be combined together for larger systems. Each input module provides its own processing with a system control module managing the flow of data to and from the recorder. A universal AC/DC power supply is provided with each chassis and there is a slot available for a redundant power supply. The hot-swappable input modules are accessible from the front of the unit.

Communications

The TR-3000 front panel has a local ethernet port for communications and USB port for configuration of the unit. The rear of the unit has dual independent ethernet ports, each with it's own IP address for configuration and data retrieval. The unit has a built-in web server for system configuration and updates. Communications are secured using SSH encryption and data can be manually or automatically retrieved using our Autocall/ Autopoll functions.

Time Sync

Several time sync options are available including a built-in GPS receiver for connecting to external antennas, IRIG-B, NTP and PTP.

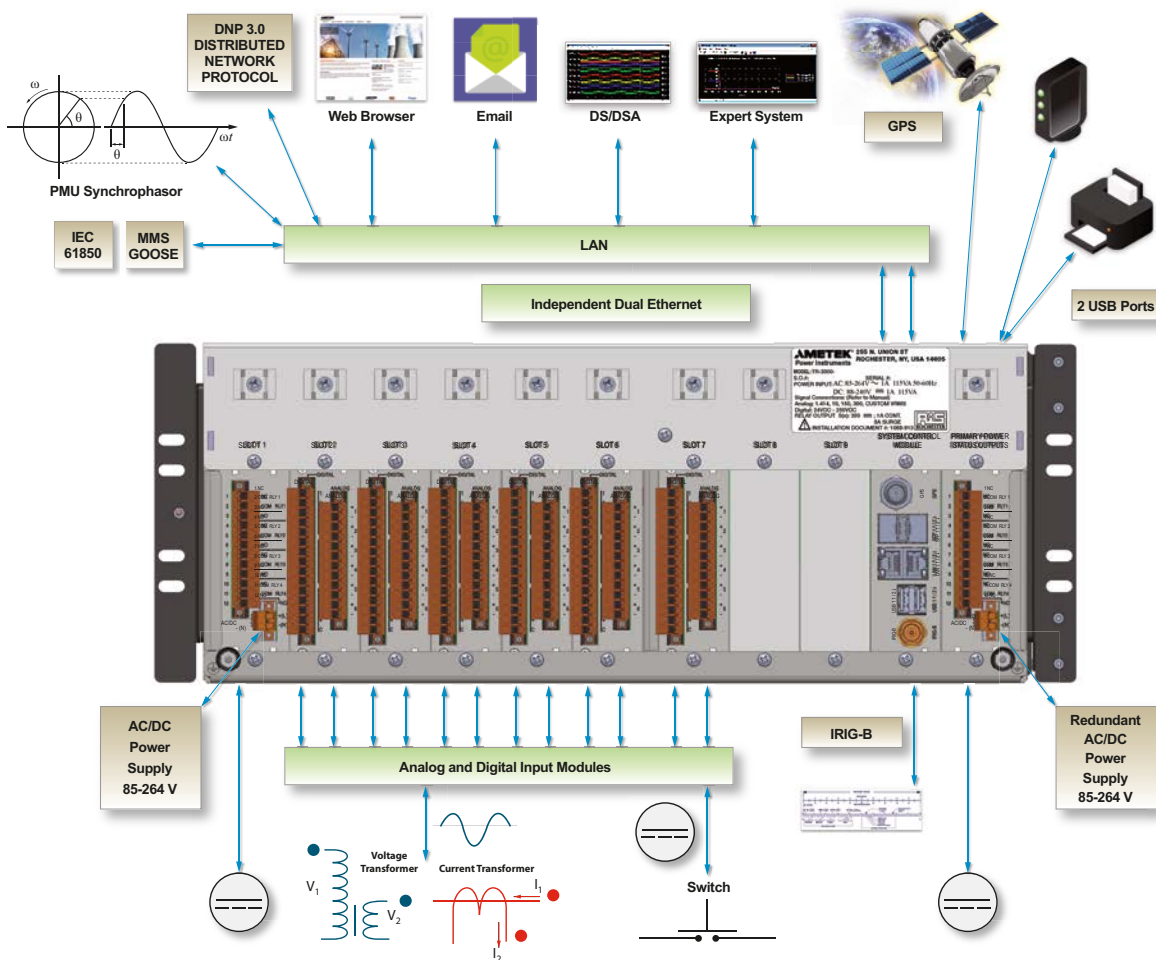

SPECIFICATIONS

INPUTS

Analog Inputs

- Built in DSP for 24-bit computations
- 16 bits Comtrade, 32768 levels (15 plus sign)
- Fixed 512 samples/cycle (26KHz/31KHz)
- Accuracy better than 0.1% of reading down to 3% of full scale

Voltage Input Ranges

- 1.414, 10, 150, 300V RMS full-scale or custom range (AC or DC compatible)

Current Input Ranges

- 1 A or 5 A RMS nominal (thru current shunts/CICTs)

Frequency Response

- DC-1/2 sampling rate (12.8kHz/15.4kHz)

Digital Inputs

- 24 to 250 VDC normally open or closed wetted contact

Input Module

- 6 analog (current or voltage) and 12 digital inputs

System Capacity (1-8 Input Modules)

- 6, 12, 18, 24, 30, 36, 42 or 48 analog
- 12, 24, 36, 48, 60, 72, 84 or 96 digital (multiple units can be tied together for even larger systems)

TRIGGERING (TRANSIENT/DISTURBANCE)

Analog Channels

- Voltage/current: over/under, rate of change (R-o-C)
- Harmonics: THD and individual harmonics (2 per channel)

Phase Group Sequence Triggers

- Over zero, over negative, over/under and R-o-C positive sequence

Frequency

- Frequency channels 1 & 2, frequency differential, over/under, R-o-C

Digital Channels

- Normal to alarm state and return to normal state. Edge or level sensitive

TRIGGERING (DISTURBANCE)

Analog Channels

- Over/under level of fundamental and R-o-C, frequency and R-o-C-o-F

Line Group Triggers

- Over/under, R-o-C
- Impedance, power factor, power factor displacement, power oscillation, power (Watts, VARs, VA)

RECORDING (TRANSIENT)

Recording Rate

- 32, 64, 128, 256 & 512 SPC (samples/cycle)
- 1.6, 3.2, 6.4, 12.8 & 25.6 kHz (50Hz)
- 1.9, 3.8, 7.7, 15.6 & 30.7 kHz (60Hz)

Pre-fault Time

- 2 to 600 cycles

Post-fault Time

- 8 to 100 cycles. Fault length extends as long as trigger condition exists.

Safety Window

- 0 to 16 cycles recording time after active trigger

Recording Duration

- 0 to 60 sec. (prevents memory filling with acontinuous trigger)

RECORDING (DISTURBANCE)

Recording Rate

- 0.5, 1.0 & 2.0 SPC
- ½, 1 or 2 X supply frequency (25/50/100Hz or 30/60/120Hz)

Pre-fault

- 10 sec. to 10 min.

Post-fault Time

- 30 sec. to 5 min. fault length extends as long as trigger point condition exists.

Safety Window

- 30 sec. to 2 min. recording time after active trigger

Recording Duration

- 60 sec. to 45 min.

Recorded Values

- Voltage and current phasor and RMS values and frequency (x2)

CONTINUOUS RECORDING (LOGGING)

Recording Rate

- 1 min

Recording Time

- 52 weeks

Stored Parameters

- Voltage and current per channel, Watts (per circuit)
- Frequency (2 channels)

CONTINUOUS RECORDING (POWER QUALITY)

Recording Rate

- 10 min

Recording Time

- 52 weeks

Stored Parameters

- Voltage imbalance, flicker, individual harmonics to 128th (W, VAR, VA)

SER RECORDING

- 1 msec. recording of all digital inputs

CONTINUOUS RECORDING (TRANSIENT OSCILLOGRAPHY)

Recording Interval

- 8, 16, 32 samples/cycle
- 400, 800, 1,600 Hz (50Hz)
- 480, 960, 1,440 Hz (60 Hz)

Recording Duration

- 1 to 64* days (depending on sample rate)

CONTINUOUS RECORDING (DISTURBANCE LOGGER)

Recording Rate

- ½, 1 or 2 x supply frequency
- (25/50/100 Hz or 30/60/120 Hz)

Recording Time

- 14-64* days (based on recording rate)

Stored Parameters

- Voltage and current phasors and RMS values and frequency (x2)

SYSTEM TIMING

Time Synchronization Accuracy

- 1 usec. or better
- Internal GPS receiver
- IRIG-B (Mod & TTL)
- Network Time Protocol (NTP)

COMMUNICATIONS

Network

- Network protocol: TCP/IP, Fiber
- 10/100 Base-TX (1 - front)
- 10/100 Base-TX (or - FX), (2 - rear)

USB Serial Ports (User Can Disable)

- 3 x USB -2 (1 - front, 2 - rear)

DATA STORAGE

Solid State Storage

- 256GB internal solid state memory

POWER SUPPLY

Input Voltage Options

- 88 to 240 VDC, 85 to 264 VAC, (optional dual redundant)

Power Requirement

- 10-65 watts depending on configuration

ENCLOSURE

Chassis

- 4U (7") 19" chassis mount

ENVIRONMENT

Operating Temperature

- 14°F to 131°F (-10°C to 55°C)

Relative Humidity

- 0 to 97% non-condensing

CERTIFICATIONS

CE (IEC 61010-1/IEC 61326-1)

STANDARDS

Complies with Power Industry Substation Standards Including:

Vibration Tests for Relays and Protection Equipment

- IEC 60255-21-(1,2,3)

Measuring Relays and Protection Equipment, Electromechanical Compatibility – For Class B Installation.

- IEC 60255-26-(IEC 61000-4-(2-12), 16-18, 29 CISPR11, 22

Electrical Equipment for Measurement, Control and Laboratory Use - EMC

- EC 61326 -1 (IEC 61000-4-(2-6,8,11)
- Environmental testing
- IEC 60068-2-(1,2,14,30)



For Customer Support

AMETEK Power Instruments
255 North Union Street
Rochester, NY 14605
Tel: +1 585 263 7700
Fax: +1 585 454 7805
power.sales@ametek.com

European Headquarters

Unit 21, Suite 6, Ridgeway
Dunfermline
Fife, United Kingdom KY11 9JN
Sales: +44 (0) 7702 809377
Fax: +44 (0) 1383 825715
power.sales-europe@ametek.com

Asia Pacific Headquarters

No. 43 Changi South Avenue 2
#04-01
Singapore 486164
Tel: +65 6484 2388
Fax: +65 6481 6588
power.sales-asia@ametek.com

AMETEK Instruments India Pvt. Ltd.

Divyasree NR Enclave, 4th Floor, Block A
Plot No. 1, EPIP Industrial Area
Whitefield, Bengaluru 560 066
Tel: +91 80 67823200
Fax: +91 80 67823232
power.sales-india@ametek.com

